



EWS 5150

Radio Emergency Warning System



ACMA Supplier Code N468

ISO9001 Certified

Blast Tone Generator

Document G/10175
Issue 5, 06/12/2013

ISSUE 5



Design Two Thousand Pty Ltd ABN: 45 005 014 639
9-11 Rose Street
Upper Ferntree Gully
Melbourne Victoria 3156 Australia
Telephone: +613 9758 5933 Facsimile: +613 9758 5560
Email: gen@design2000.com.au
Web Site: www.design2000.com.au

**All Rights Reserved,
Copyright © 2013, Design 2000 Pty Ltd**

PAGE LEFT BLANK

Document Control

| | | | |
|------------------------|---------------------------------|-------------|-----------------------------------|
| Document ID | G/10175 | | |
| Document Name | EWS 5150 Handbook | | |
| Security | Public Domain | | |
| Circulation | Design 2000 Pty. Ltd., Motorola | | |
| Prepared By | P. Zeug | | |
| Reviewed By | Damien Tyrrell | | |
| Approved By | Roger Noble | | |
| Version Control | Edition | Date | Notes |
| | Draft 1 | 30/04/2010 | Draft only |
| | Draft 2 | 03/05/2010 | Brief description of email alerts |
| | Issue 1 | 28/03/2011 | XTL2500/5000 added |
| | Issue 2 | 01/04/2011 | General Release |
| | Issue 3 | 09/06/2011 | Activating the Blast Tone |
| | Issue 4 | 29/09/2011 | Revised XTL connections |
| | Issue 5 | 06/12/2013 | DM4601 connection added |

© Copyright 2013, Design 2000 Pty Ltd

PRINTED IN AUSTRALIA

- Contents -

| | |
|--|-------------|
| INTRODUCTION | PAGE |
| Description and User instructions | 3 |
| Ethernet Comms | 3 |
| Changing the Tones | 5 |
| Configuration over the Local Area Network | 5 |
| EWS Alert emails | 7 |
| CONNECTIONS | |
| EW-5150 to MTM800 Accessory Connector Pinouts | 7 |
| Activating the Blast Tone | 7 |
| EW-5150 to XTL2500 Accessory Connector Pinouts | 8 |
| EW-5150 to DM4601 MAP Connector Pinouts | 8 |
| FRONT & REAR PANEL DESCRIPTIONS | |
| Front Panel Indicators | 9 |
| Rear Panel Connections | 10 |
| MP3 Volume Normalization | 11 |
| SPECIFICATIONS | 12 |
| Part Numbers | 14 |

EMERGENCY WARNING SYSTEM

MODEL EW-5150 Blast Tone Generator

DESCRIPTION & USER INSTRUCTIONS

The EW-5150 is an Emergency Warning System (EWS) for a radio network. It is also referred to as a Blast Tone Generator that plays a warning tone over the radio network prior to the commencement of blasting at mine sites.



It utilizes a Motorola MTM700/MTM800 TETRA ZEON mobile radio, an XTL2500/XTL5000 ASTRO APCO P25 mobile radio or DM4601 MOTOTRBO™ mobile radio. The radio is connected to the EW-5150 via the Control Box CB-5133 with a custom made cable, part number CA-5154MTM, CA-5154XTL or CA-5154TRBO.







A mining operator can place a private call to the radio (MTM) or page/alert the radio (XTL) which triggers the External Alarm function, activating the Emergency Warning System blast tone. There is also the option of using a momentary push button switch to start and stop the blast tone.

By default the EWS, when triggered by a private call or page to the radio, will transmit a two-tone warning for 10 seconds. The default two-tone warning alert consists of alternating frequencies of 420 Hz & 700 Hz each of 500 ms duration. The EWS then stops transmitting for 20 seconds before transmitting the two-tone alert again.

This sequence is repeated until manually cancelled by another private call or page to the radio, or automatically after the Master Timer of 10 minutes (programmable) expires.

The EWS can also play a routine awareness/comfort tone that lets miners know they have radio contact.

The EWS has its own internal Homepage. Using a Web browser, authorized installers and operators can change various operational parameters and these include:

-  DHCP
-  Email Alerts
-  Delay/interval between Warning (Blast) Tone transmissions
-  Total master timer for Warning (Blast) Tone cycle
-  Awareness Tone timer (Setting 0 = off)
-  Warning Tone volume level

ETHERNET COMMS

On the EW-5150 back panel is an Ethernet jack which is the TCP/IP interface to the LAN/WAN and the Internet. A standard CAT5 patch cable (supplied) is used to connect the EW-5150 to an Ethernet Switch, Router or Broadband modem.

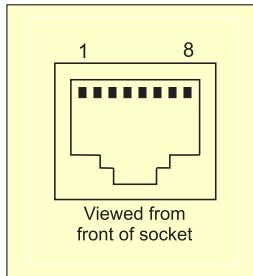

| PIN | DESCRIPTION |
|-----|----------------------|
| 1 | TXD + Pair 3 (T568A) |
| 2 | TXD - Pair 3(T568A) |
| 3 | RXD+ Pair 2 (T568A) |
| 4 | Not connected |
| 5 | Not connected |
| 6 | RXD- Pair 2 (T568A) |
| 7 | Not connected |
| 8 | Not connected |

Changing the Warning Tone and Awareness Tone files using an External Card Reader

The SD Card can be ejected from the EW-5150 by applying gentle pressure, causing it to pop out of the slot. It can then be inserted into a Card reader and be seen as a mass storage device. New MP3 files can simply be 'dragged' across to the Card but you will need to erase existing files by re-formatting the card as a FAT or FAT16 file system before new files are 'dragged and dropped' within Windows. You must also copy 1.mp3 first, then 2.mp3.

Notes:

- Files **must** be named as follows:
 1. Awareness Tone: 1.mp3
 2. Alarm Tone: 2.mp3
- It is highly recommended that MP3 recordings have their volume normalized to 96.0 using the MP3Gain freeware program.
- The MP3 files can be voice announcements rather than tones, or a combination.
- SD Cards are 'hot swappable'. There is no need to remove power from the EW-5150. Playing automatically commences when another loaded SD Card is inserted and an Alarm call is received.

Configuration over the Local Area Network

The integrated Homepage Control Panel allows you to configure your DHCP, Username, Password and other settings. This internal configuration can only be done on your LAN.

Launch your Internet Browser and enter Browser Config Address WX[serial number] eg. WX1514. You'll find the Browser Config Address (NetBIOS name) on the base of your EW-5150. The internal Homepage control panel will appear (see next page):

MOTOROLA
EMERGENCY WARNING SYSTEM

Firmware Version: v1.00 Firmware Build Date: Feb 05 2010 19:45:42

Network Settings

| | | |
|-----------------------|---|---|
| DHCP: | <input checked="" type="checkbox"/> Enabled | Usually enabled. Only disable this option if you need to assign a fixed IP. Your hostname is: WAVECUBE |
| IP Address: | <input type="text" value="192.168.1.8"/> | Be careful to set this to a valid network IP or you may lose connection. |
| Subnet Mask: | <input type="text" value="255.255.255.0"/> | Usually 255.255.0.0 or 255.255.255.0 |
| Gateway: | <input type="text" value="192.168.1.1"/> | Usually your router's IP (eg. 192.168.0.1) |
| MAC Address: | 00:50:C2:7B:80:00 | The last two bytes of MAC are automatically derived from the Serial No. |
| Serial Number: | <input type="text" value="0"/> | The Serial No. is preset at the factory and cannot be changed. |

Server Settings

| | | |
|-------------------------|---|--|
| Email Alerts: | <input type="checkbox"/> Enabled | Enable this option to allow the Wavecube to send alert e-mails. |
| Email Address: | <input type="text"/> | Email address for alerts. (35 chars max) |
| Email Server: | <input type="text" value="www.wavecube.com"/> | This is the email server. (eg. mail.wavecube.com) (35 chars max) |
| Server Username: | <input type="text"/> | This is your server Username. (35 chars max) |
| Server Password: | <input type="text"/> | This is your server Password. (20 chars max) |
| Server Port: | <input type="text" value="25"/> | Usually 25. Do not change this without good reason. |

Alarm Settings

| | | |
|---------------------------------------|----------------------------------|--|
| Alarm Repeat Delay: | <input type="text" value="20"/> | Seconds between alarm repeats (default: 20) |
| Total Alarm Time: | <input type="text" value="10"/> | Total alarm time in minutes (default: 10) |
| Awareness Tone Repeat Delay: | <input type="text" value="120"/> | Seconds between awareness tone repeats (default: 120) |
| Channel Activity Silence Time: | <input type="text" value="7"/> | Seconds of silence required before alarm can sound (default: 7) |
| Retry Timeout: | <input type="text" value="2"/> | Minutes to retry to play alarm before sending failure email (default: 2) |

http://wavecube/ (1 of 2) [30/04/2010 2:05:25 PM]
 Wavecube Configuration System

Sound Settings

| | | |
|----------------|--------------------------------|--|
| Volume: | <input type="text" value="8"/> | This is the sound level of your Wavecube. Enter a value in the range of 1 (softest) to 10 (loudest). |
|----------------|--------------------------------|--|

Security Settings

| | | |
|------------------|----------------------|---|
| Password: | <input type="text"/> | Enter a case-sensitive password (10 digits max) used to access this configuration page. It can be upper and lowercase letters and numbers. Leave blank for no password. When requested, enter this password and the username "admin". |
|------------------|----------------------|---|

Copyright 2010, Design 2000 Pty. Ltd.
 www.design2000.com.au

Check the appropriate boxes and set the required parameters then click on 'Save Changes & Reboot'.

EWS AUTO-MAILER EMAIL SUCCESS/FAILURE NOTIFICATION

If the EWS is prevented from transmitting the blast tone, it can send an alert email to the email address set in the configuration system:

Eg. "EWS wavecube X-Stream serial no.1514 (IP:114.77.102.19) failed to deliver message 2.mp3 (blast tone) on Thursday, November 10, 2009 at 1:15PM. Channel still busy after five attempts
Input 1 (COS) is Low (active).
Output 2 (PTT) is Low (inactive).
Volume is set to 8.
Note: This is an auto-generated email and cannot be replied to."

CONNECTION MTM, XTL & TRBO Series

EW-5150 EXTERNAL CONTROL TO MTM700/MTM800 ACCESSORY CONNECTOR

Connections between the External Control connector on the EW-5150 and the Accessory connector on the MTM700 or MTM800 provide the signal paths required for the EWS to operate. These are listed in the table below:

| Signal Description | EW-5150 Isolated Audio & External Control | MTM800 Accessory Connector | Notes |
|---------------------------|---|----------------------------|------------------------------------|
| Analogue ground | 3 | 7 | |
| Audio out to radio | 4 | 2 | Isolated |
| N/C | 1 | | |
| External Alarm from radio | 2 | 4 | Via K1 |
| PTT to radio | 3 | 3 | Via Q1 |
| Rx Carrier from radio | 4 | 5 | Via K2 |
| Digital Ground | 5 | 8 | Connects to K1 & K2 |
| SWB+ | | 13 | Connects to K2 |
| EW-5150 power | 2.1mm concentric | | 12Vdc 350mA plug pack (centre +ve) |

- A special cable, part number CA-5154MTM, contains relays K1 and K2, transistor Q1 and protection diodes D1 & D2.
- The MTM700/800 radio must be modified to provide Rx carrier indication on pin 5.

Activating the Blast Tone

MTM

For the blast tone to sound, the External Alarm (pin 4) of the MTM800 needs to go low (0V) for more than 100ms and then go high (12V) within about 10 seconds. This sequence is then repeated to stop the blast tone.

XTL

For the blast tone to sound, VIP OUT 1 (pin 18) of the XTL2500 needs to go low (0V) for more than 100ms and then go high (12V) within about 10 seconds. This sequence is then repeated to stop the blast tone. Please note that a momentary push button can be used for the activation and deactivation of the blast tone – see next page.

EW-5150 EXTERNAL CONTROL TO XTL2500/5000 ACCESSORY CONNECTOR

Connections between the External Control connector on the EW-5150 and the Accessory connector on the XTL2500 or XTL5000 provide the signal paths required for the EWS to operate. These are listed in the table below:

| Signal Description | EW-5150 Isolated Audio & External Control | XTL2500 Accessory Connector | Notes |
|---------------------------------------|---|-----------------------------|---|
| Analogue ground | 3 | 23 | |
| Audio out to radio | 4 | 1 | Isolated |
| N/C | 1 | | |
| External Alarm from radio (VIP OUT 1) | 2 | 18 | Normally high, connects via K1 |
| PTT to radio | 3 | 16 | Connects via Q1 |
| Rx Carrier from radio (CHAN ACT) | N/C (4) | N/C (13) | Optional connection, normally not connected |
| Digital Ground | 5 | 14 | Connects to K1 & K2 |
| SWB+ (12V) | | 24 | Always 12V when radio is on, connects to K2 |
| Manual Start/Stop switch | 2 | | Momentary push button N/O |
| | 5 | | Momentary push button COM |
| EW-5150 power | 2.1mm concentric | | 12Vdc 350mA plug pack (centre +ve) |

EW-5150 EXTERNAL CONTROL TO MOTOTRBO™ DM4601

CB-5133 TO TRBO RADIO INTERFACE CABLE

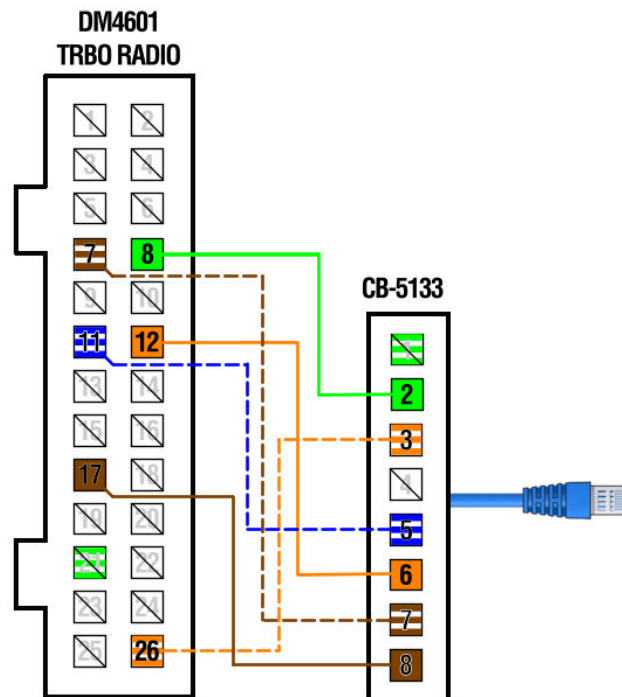

T568A WIRING COLOURS

| CB-5133 PL1 CONTROL CONNECTOR RJ45 | RADIO ACCESSORY CONNECTOR PMLN5072A | DESCRIPTION | T568A COLOUR |
|------------------------------------|-------------------------------------|-------------|---------------|
| 1 | NC | | (GREEN/WHITE) |
| 2 | 8 | PWR GND | GREEN |
| 3 | 26 | VIP-1 | ORANGE/WHITE |
| 4 | NC | | (BLUE) |
| 5 | 11 | TX AUDIO | BLUE/WHITE |
| 6 | 12 | AUDIO GND | ORANGE |
| 7 | 7 | SW B+ | BROWN/WHITE |
| 8 | 17 | PTT | BROWN |

FRONT PANEL INDICATORS



Power

The red **POWER** LED indicates that 12Vdc, 350mA power is connected.

Play

The green **PLAY** LED indicates that the file(s) on the SD Card are currently playing. When the SD Card is ejected, this LED will flash.

Steady: An SD Card is inserted and an MP3 audio file is playing.

Slow flash: No SD Card is inserted.

Load

The yellow **LOAD** LED indicates that the EW-5150 is in the process of downloading a new MP3 file from wavecube.com. When the SD Card is ejected, this LED will flash.

On: A new MP3 file is downloading & being written to the SD Card (future feature).

Off: An SD Card is inserted and an MP3 audio file is playing.

Slow flash: No SD Card is inserted.

SD Card Slot backlight

The blue LED backlight glows steadily to indicate the proper insertion of a FAT16 (FAT) formatted SD Card.

REAR PANEL CONNECTIONS

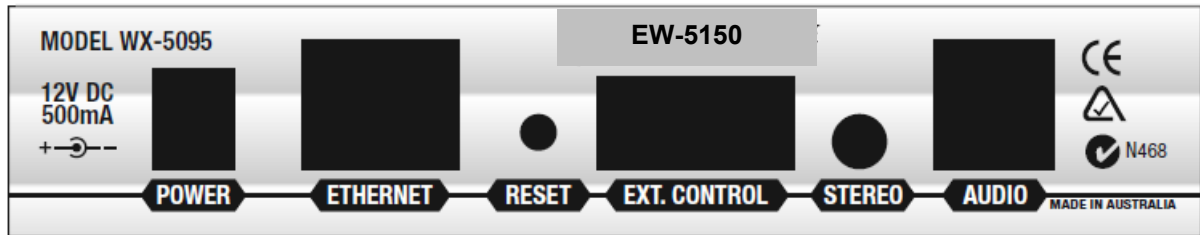

3.1 Power

The EW-5150 runs from a 12Vdc power source. It draws less than 300mA . As standard, the unit is supplied with an approved 240Vac / 12Vdc, 350mA power adaptor with a concentric dc power plug, 2.1mm centre pin positive.

3.2 Audio Out

The isolated audio is output on the RJ12 jack for connection to the radio external mic audio in. The default output is around 500mV p-p however this can be adjusted on the EW-5150 web page. There is an inbuilt Line Isolation Unit (LIU) so there is no need to have an external LIU.

Audio Feed – use the RJ12 jack with the inbuilt LIU. It sends isolated mono (or stereo combined to mono) audio.

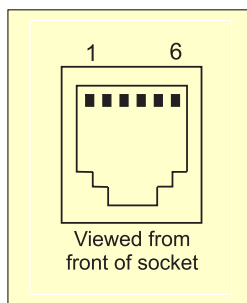

| PIN | DESCRIPTION |
|-----|---|
| 1 | Not connected |
| 2 | Not connected |
| 3 | Ring (Lb) – Sleeve, ground return |
| 4 | Tip (La) – Signal, left & right audio mixed to mono |
| 5 | Not connected |
| 6 | Not connected |

MP3 VOLUME NORMALIZATION

MP3 files should be 'normalized' prior to uploading. This is to maintain consistent output levels. An MP3 normalization program called MP3Gain is recommended for this purpose. It is freeware however it would be appreciated if you made a donation to the authors:

Download page:

<http://mp3gain.sourceforge.net/download.php>

Direct link to download current version:

http://optusnet.dl.sourceforge.net/sourceforge/mp3gain/mp3gain-win-1_2_5.exe

Tip! Use the setting 'Volume 96.0' when applying track gain to MP3 files. Use 'Track Gain' rather than 'Constant Gain'.

EW-5150 SPECIFICATIONS



Indicators

Displays Power LED (Red), Load LED (Yellow), Play LED (Green), SD card slot backlight (Blue).

Message Upload/Playback

| | |
|---------------------------|--|
| Message upload | PC Card reader. |
| MP3 decoder | MPEG-1 Audio Layer 3 (ISO11172-3), supports MPEG 1 & 2 and 2.5 extensions. |
| Sample & bits rates | Mono or stereo. |
| MP3 Encode Rate | 8 kbits/s to 320 kbits/s CBR (Constant Bit Rate), supports VBR (Variable Bit Rate) to a peak of 320 kbits/s. |
| Recommended MP3 bit rates | 64 kbits/s mono for messages, ≥ 128 kbits/s for music. |
| Upper pass band | 10 kHz. |
| Message retention | > 100 years. |
| Upload cycles | > 100,000 writes to any one memory cell. |
| Read cycles | Unlimited. |
| Messages length | SD/MMC Card dependent, encode rate dependent. |
| Memory Card support | SD or MMC up to 1GB capacity, FAT16 (FAT) file system format. |

Processor

| | |
|--|---|
| Type | PIC18F97J60 |
| Processor Speed | 25 MHz XTAL, internally multiplied to 41.667 MHz. |
| On Board RAM | 3.7KB. |
| On Board Ethernet Buffer | 8KB. |
| On Board FLASH | 128KB. |
| External EEPROM for settings and internal web page storage | 32KB. |

Back

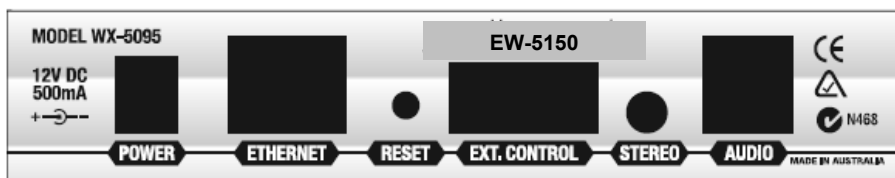

Analogue Audio Out

| | |
|----------------------|---|
| Audio Out connectors | 3.5 mm stereo phone jack for headphones/line out RJ-12 6P2C socket (isolated) for radio |
| Output level | < 2V p-p, 1V p-p default (software adjustable) |
| Frequency range | 40 Hz \rightarrow 10 kHz (on stereo connector) 300 Hz \rightarrow 3.4 kHz (on isolated audio socket) |

Data Communication

Ethernet 10Mbps

External Control

Pin 2 Input for Alarm from radio, active low
Pin 3 Output for PTT to radio, active low
Pin 4 Input for Carrier detect from radio, active low (not connected for XTL series)
Pin 5 Ground

General

Operating Environment

| | |
|---------------------------------|------------------------------|
| Operating Temperature Range | -10 → +60 ° C |
| Storage Temperature Range | -20 → 80 ° C ambient |
| Humidity, Storage and Operating | To 98% non-condensing |
| Mean Time Between Failure | > 20 years |
| Safety | Complies with AS/NZS 60950 |
| EMC | Complies with AS/NZS CISPR22 |
| ACMA Supplier Code Number | N468 |
| ERAC Responsible Supplier No. | E1287 |
| Warranty | Two years |

PART NUMBERS

| | |
|---------------|---------------------------------|
| EW-5150 | EWS Unit (Blast Tone Generator) |
| CB-5133 | Control Box |
| CA-5154MTM | Interface Cable |
| CA-5154XTL | Interface Cable |
| CA-5154TRBO | Interface Cable |
| MTM700/MTM800 | Motorola TETRA Radio |
| XTL2500/5000 | Motorola P25 Radio |
| DM4601 | MOTOTRBO™ Radio |

Designed and Manufactured in Australia



Design Two Thousand Pty Ltd
Melbourne Australia

Telephone: 03 9758 5933
Facsimile: 03 9758 5560
Email: gen@design2000.com.au
Web site: www.design2000.com.au



N468

